

Special caliper

S_Cal EVO

DESCRIPTION

SMART INTERNAL GROOVE

- **Integrated Bluetooth® wireless technology**

- Special jaws for measuring grooves and internal seatings
- Programmable button according to your needs
- Water protected for heavy-duty work with coolants and lubricants, protection rating IP67 according to IEC 60529,
- Automatic wake-up by moving the electronic on his frame. (Absolute System S.I.S)
- Sleeping mode after 10 min. of no use. (Absolute System S.I.S)
- Position memorized in sleeping mode, **Absolute System S.I.S***
- Maximum speed of displacement : 2.5 m/sec
- Mechanical frame in stainless steel, hardened and grinded
- Great comfort of use thanks to its ergonomic frame

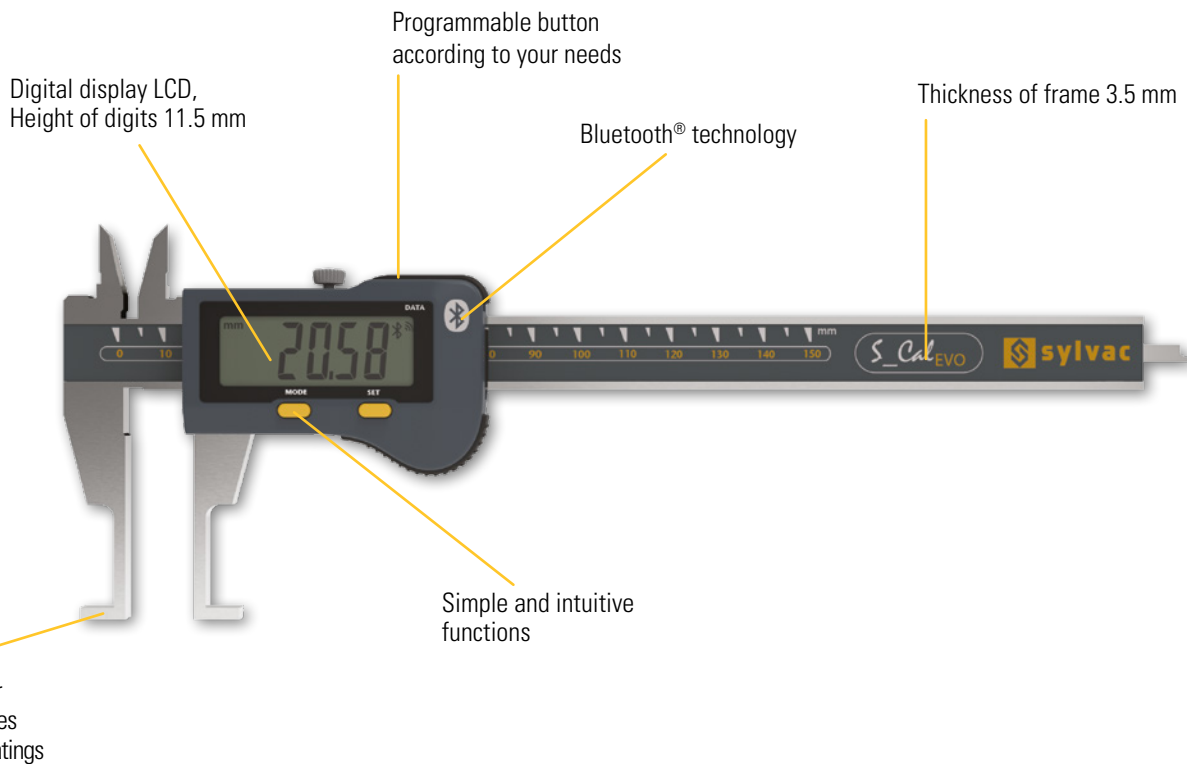

For measuring grooves and internal seatings



* SIS description on page 5

Special caliper

S_Cal EVO

DIMENSIONAL DRAWING

SMART INTERNAL GROOVE

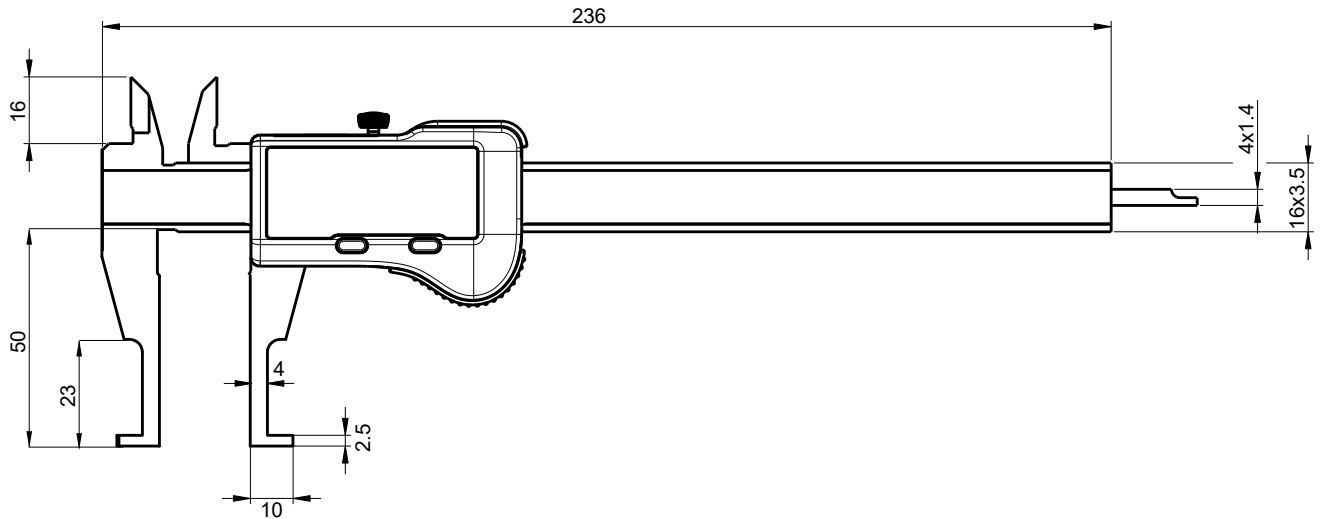

C

TECHNICAL SPECIFICATIONS

		810.1600
Measuring range	mm	150
Max. Error G	µm	20 ¹⁾
Depth rod	mm	— 4 x 1.4
Protection rating according to IEC 60529		IP67
Output data		Bluetooth® wireless technology*
Functions		Zero setting, Preset (max 999.99), mm/inch, Hold, Data
Smart Inductive Sensor		●

¹⁾ > 100 mm : 30 µm / DIN 862